

1

**RIXSON®**  
**Yale Security Inc.**  
 1902 Airport Road, Monroe, NC 28110  
**990 Door Release**  
**IS-990-1A** 2-00

**INSTRUCTIONS:**

- To locate junction box use table below.
- Determine door width (Dim. "B"). Measure pivot centerline to wall (Dim. "A"). Find dimension "C" in table.  
 Example: Pivot centerline to wall ("A") = 10"  
 Door Width ("B") = 36"  
 Junction Box Centerline ("C") = 33"
- If "A" or "B" falls between the numbers listed in table allow for difference.  
 Example:  
 Pivot centerline to wall ("A") = 17"  
 Door Width ("B") = 36"  
 Junction Box Centerline ("C") = 30-1/4"

- If dimensions "A" and "B" intersect in shaded area of table **do not install junction box**. The degree of door opening will not permit proper alignment between armature and wall magnet.
- Vertical location determined by others suggested height not over 6'-0"
- Check degree of door opening in table and coordinate with door closers and other door hardware.

"A" – Pivot Centerline to Wall  
 "B" – Door Width  
 "C" – Pivot Centerline to Junction Box Centerline

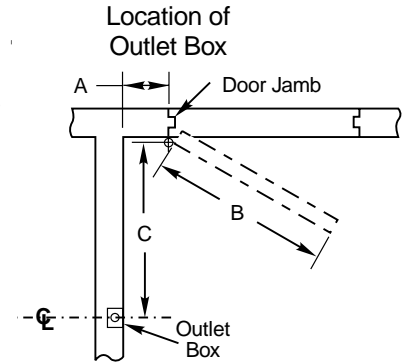

Dim. "A"	Door Width "B"																					
	28		30		32		34		36		38		40		42		44		46		48	
	"C"	Deg.	"C"	Deg.	"C"	Deg.	"C"	Deg.	"C"	Deg.	"C"	Deg.	"C"	Deg.	"C"	Deg.	"C"	Deg.	"C"	Deg.	"C"	Deg.
2	26	92°	28	92°	29-7/8	92°	32	93°	34-1/8	93°	36	92°	37-7/8	92°	40	93°	42	93°	43-7/8	92°	45-5/8	92°
4	26	97°	28	96°	29-7/8	96°	32	95°	34-1/8	95°	36	95°	37-7/8	95°	40	95°	42	95°	43-7/8	94°	45-5/8	94°
6	25-5/8	102°	27-5/8	101°	29-5/8	100°	31-3/4	99°	33-3/4	98°	35-3/4	97°	37-3/4	97°	39-7/8	97°	41-7/8	97°	43-3/4	97°	45-1/2	97°
8	25-1/8	106°	27-1/4	105°	29-1/4	104°	31-3/8	103°	33-1/2	102°	35-1/2	101°	37-3/8	101°	39-1/2	101°	41-1/2	101°	43-3/8	100°	45-1/4	99°
10							31	105°	33	106°	35	105°	37	104°	39-1/8	104°	41-1/8	104°	43-1/8	103°	45	102°
12																			42-5/8	105°	44-1/2	104°

All dimensions given in inches.

- All junction box anchoring shall withstand 50 pounds of pull or push force.
- Verify line voltage.
- See page B to complete this installation

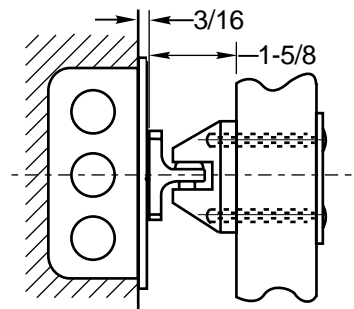

**1 See page A for junction box location**

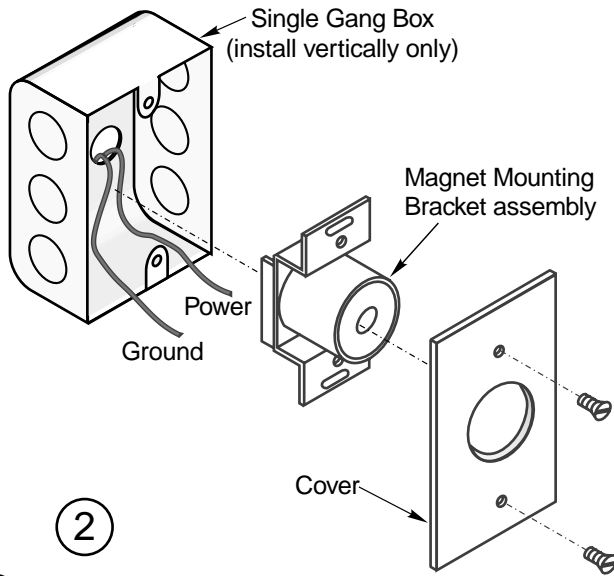

**2 Connect power**

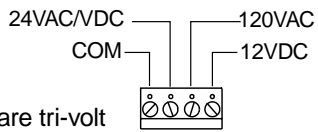

- For coils that are tri-volt put Ground wire in "Com". Put power wire in correct voltage slot on strip.
- For coils with two wires attach one wire to ground. Attach one wire to power. Coil is non-polarized so it doesn't matter which wire is attached to which.

**4 Loosen Contact Plate Adjustment Screw**

**5 Remove Paper**

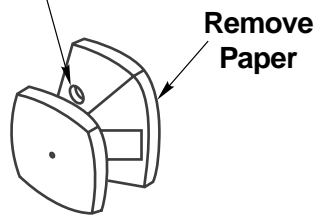

**3 Attach Cover & magnet mounting bracket assembly to junction box**

**6 Turn Power On**

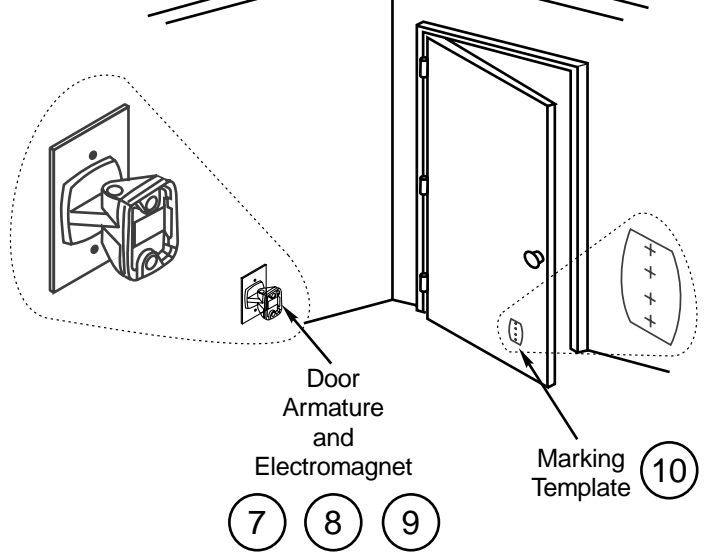

- 7 Place armature flat on coil.** Make sure round solenoid is completely covered by contact plate.  
\*\* If coil cannot be energized yet, hand hold contact plate on magnet and complete next steps.
- 8 Open door against armature on wall.**
- 9 Tighten contact plate on armature.**
- 10 Pull door away leaving mounting template sticking to face of door.**

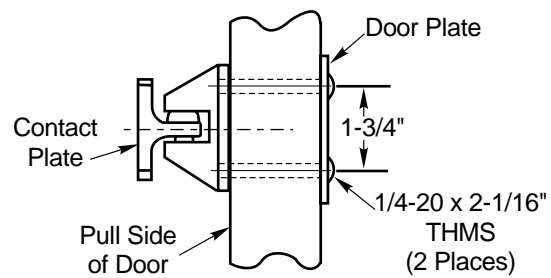

**THRU BOLT**

Hollow Metal, Hollow Core Wood or Composite Doors

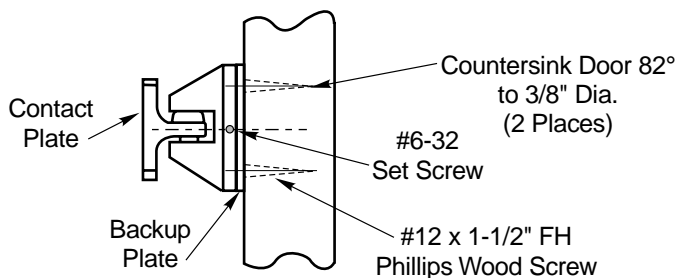

**SURFACE MOUNT**

Solid Wood Doors

**12 Affix to door.**

**11 Select thru bolt or surface mounting option.**

**RIXSON**<sup>®</sup>  
**Yale Security Inc.**  
 1902 Airport Road, Monroe, NC 28110

---

**990 Door Release**

---

**IS-990-1B**